

DELCO

MECHANICAL SEALS

For Centrifugal and Chemical Pumps,
Agitators, Compressors, Refineries, Supply
Systems and Similar Applications

WORLD SEAL
Mechanical Seals

integrity and
improved
efficiency

THE MAIN FOCUS OF DELCO GROUP IS DELIVERING
MAXIMUM VALUE AND HIGH QUALITY LEVEL PRODUCTS

**DELCO**
Quality assured
Printed in Canada

ELASTOMERIC BELLOWS AND MULTI
SPRINGS MECHANICAL SEALS



MATERIALS

TYPE DM

TYPE DL

TYPE DU

SEATS

QUALITY ASSURED

ELASTOMERIC BELLOWS AND MULTI-SPRINGS MECHANICAL SEALS



Materials

Material Identification and Coding

Bellows Material

- E** - EPDM Ethylene propylene Diene M-class rubber
- P** - NBR Nitrile Butadiene Rubber
- V** - VITON® fluoro-carbon rubber
- K** - KALREZ® prefluoro-carbon rubber
- T** - PTFE (TEFLON®)
- G** - Compressed graphite
- X** - FLUORAZ®
- A** - AFLAS®



Spring(s)

- M** - Hastelloy C4 DIN 2.4610
- G** - AISI 316 DIN 2.4571
- F** - AISI 304 DIN 1.4301
- M5** - Hastelloy C276 DIN 2.4819
- T6** - AM 350 special alloy
- S** - Chromium-molybden steel



Stationary rings

- Q1** - SiC sintered silicon carbide
- Q2** - SiC reaction bonded silicon carbide
- U3** - Tungsten carbide
- V** - Aluminum oxide (ceramic 95%)
- V2** - Aluminum oxide (ceramic 97%)

Rotary rings

- A** - Antimony-impregnated carbon graphite
- B** - Carbon graphite
- Q1** - Sintered silicon carbide
- Q2** - Reaction bonded silicon carbide
- U3** - Tungsten carbide

Construction material(s)

- G** - AISI 316
- F** - AISI 304
- M5** - Hastelloy C276
- T4** - Carpenter 42
- T6** - AM 350 special alloy
- S** - Chromium-Molybden steel



Elastomeric Mechanical Seals

ELASTOMERIC BELLOWS AND MULTI SPRINGS MECHANICAL SEALS



Operating principles and Fundamentals Behind Elastomeric Rotary Mechanical Seal

Centrifugal and rotary positive displacement pumps require controlling of the pumped fluids desire to exit through the stuffing box, the area where the pump shaft enters the pump fluid end.

When operating the pumped fluid within the stuffing box sees a pressure higher than the surrounding atmospheric pressure, and on static lift applications; during the priming cycle, the stuffing box will see a pressure below atmospheric pressure i.e., a vacuum. In either operating condition a mechanical seal will virtually eliminate the release of the pump age to atmosphere and the entrance of air into a stuffing box when under vacuum.

A basic mechanical seal is not a complex device. It consists primarily of a rotary seal face with a driving mechanism which rotates at the same speed as the pump shaft, a stationary seal face which mates with the rotary and is retained using a gland or in some pump models an integral stuffing box cover, a tension assembly which keeps the rotary face firmly positioned against the stationary face to avoid leakage when the pump is not in operation, and static sealing gasket(s) and elastomeric strategically located to complete the seal assembly.

The rotating and stationary sealing faces commonly referred to as primary seal members, are materials selected for their low coefficient of heat and are compatible with the fluid being pumped. Their extremely flat; lapped mating surfaces, make it extremely difficult for the fluid to escape between them. The fluid does however, forms a thin layer or film between the faces and migrates toward the low pressure side of the faces. It is this boundary layer of fluid which is used and required to cool and lubricate the seal faces.

To prohibit leakage along the pump shaft through the inside diameter of the rotary and stationary seal faces the mechanical seal assembly uses o-rings, v-rings, wedges and packing. Commonly referred to as secondary sealing members these components of the seal are selected based on fluid compatibility, temperature, elastomeric quality, and depending on the type and design of the seal they may perform in either a dynamic or static state.

Mechanical seal hardware represents the components required to apply mechanical tension to the rotating and stationary seal faces. This hardware; depending on seal design, can include springs, bellows, retaining rings, and pins. Not to be overlooked hardware materials must be constructed of suitable metallurgy compatible with the fluid. An appreciation of seal driving hardware is also extremely important when sealing viscous products as ample torque to rotate the seal must be made available when the fluid is at its standing viscosity when starting a pump, and effective viscosity at operating conditions.

Mechanical seal selection should never be addressed as simple, easy or standard, as it is this approach which results in inadequate performance. A mechanical seal will only perform as well as all the sealing components combined and any options and auxiliary systems which may be required. Failure to properly address any portion of the mechanical seal chain could result in catastrophic failure, down time, considerable damage and expense, and most importantly personal injury and possible damage to the environment.

Specific pumping application requirements will determine the complexity of the seal design to achieve optimum performance. Mechanical seal configurations and options are as vast as pump models and designs. Addressing all the application parameters and fluid behavior characteristics will result in long trouble free mechanical seal service and enhanced pump and process performance.



Elastomers and Rubber Identification

KALREZ®

Perfluoroelastomer

Kalrez is a registered trademark of DuPont Performance Elastomers L.L.C. These parts are based on perfluoroelastomeric material which is compounded and molded into O-rings, gaskets, mechanical seals and specialty parts. Kalrez has excellent resistance towards temperature and chemicals, some grades have a maximum continuous service temperature of 346°C.

perfluoroelastomeric (FFKM) O-rings and gaskets are generally used in applications of aromatic hydrocarbons and in highly corrosive fluids and can generally withstand to a temperature of -7 degree Celsius to maximum of 480 degree Celsius, at which point the material decomposes.

VITON®

Viton is a registered trademark of DuPont Performance Elastomers L.L.C.

and is an excellent elastomeric for use in high temperature applications. Also exhibits excellent chemical resistance to use in harsh environments such as phosphate esters. Widely used in applications dealing with extreme temperature and/or extreme chemicals. It is suitable to use with most chemicals. Makes it a popular elastomeric in chemical processing, paper / pulp mills, various chemical, acid and solvent applications. Use in tough sealing applications requiring extreme chemical resistance such as O-Rings, Hydraulic seals, Pneumatic seals and mechanical seals.

TEFLON®

Teflon is a registered trademark of E.I. DuPont de Nemours and Company (DuPont).

The molecular structure of PTFE consists of long chains of carbon atoms fully saturated by fluorine atoms. PTFE component parts for applications that require the high purity, chemical resistance, and thermal & electrical properties of performance and display exceptionally low coefficients of friction. Teflon fluoropolymer resins have exceptional resistance to high temperatures, chemical reaction, corrosion, and stress-cracking and can be used to fabricate o-rings, gaskets, mechanical seals and mechanical parts.

AFLAS®

Aflas is the trademark of AGC Chemicals, Asahi Glass Co. Ltd.

Aflas is resistant to highly reactive organic and inorganic chemicals. Aflas is highly resistant to automotive oils heavily formulated with amine additives. Aflas is suitable even in dirty environments, such as gear seals, mechanical seal and can be used to fabricate o-rings, gaskets, seals, packing where PTFE resin seals are not suitable.

FLUORAZ®

By Greene, Tweed & Co.

Fluoraz delivers an excellent performance in a variety of harsh environments, including the deep-well drilling, chemical, petrochemical, aerospace, automotive and refining industries. This versatile compound outperforms fluorocarbon and other conventional elastomers, even in the most severe circumstances. Fluoraz is derived from a modified structure of tetrafluoroethylene and propylene copolymers, providing significantly longer and more reliable service in a broad range of fluids, especially at elevated temperatures. Standard and customized. Its excellent performance in steam, hot water and nearly all caustics allows it to be the elastomer of choice in sterile water-for-injection, clean steam, and steam-in-place and clean-in-place systems.

ELASTOMERIC BELLOWS AND MULTI SPRINGS MECHANICAL SEALS

Material Applications



Elastomeric Temperature and Application Limit

Elastomer	Code	Min.	Temperature limit	Max.	Application
PTFE	T	- 75 °F / - 60 °C		500 °F / 260 °C	Chemical resistant (General)
KALREZS®	K		20 °F / - 7 °C	650 °F / 346 °C	High Temperatures and Chemical application
FLUORAZ®	X	- 22 °F / - 30 °C		500 °F / 260 °C	High temperature and chemical application
VITON®	V	- 22 °F / - 30 °C		400 °F / 204 °C	Oil field and general application
NBR	P	- 40 °F / - 40 °C	250 °F / 121 °C		General duties
EPDM	E	- 40 °F / - 40 °C	300 °F / 149 °C		Hot water and general duties
NEOPRENE	N	- 22 °F / - 30 °C		500 °F / 260 °C	Refrigeration application
AFLAS®	A	14 °F / - 10 °C		573 °F / 300 °C	Oil, industrial field, steamed high chemical application

Best Performance and Working Temperature Condition For Seals Ring

Material	Max. Temperature
Solid Tungsten Carbide	750°F 400°C
Solid Carbon-graphite	525°F 275°C
Solid Reaction Bonded Silicon Carbide	800°F 430°C
Solid Sintered Silicon Carbide	800°F 430°C
Solid Antimony Impregnated Carbon Graphite	700°F 370°C
Solid Pure Ceramic (Al2O3)	350°F 180°C

TYPE DL



ELASTOMERIC BELLOWS ROTARY MECHANICAL SEAL FOR PLAIN SHAFT, SPRIG ROTATING

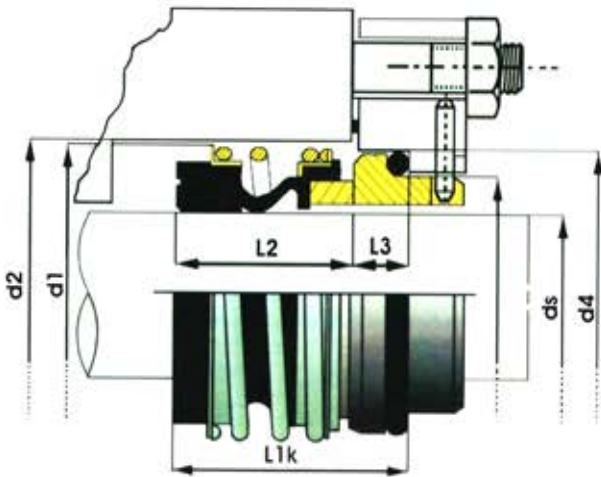

DL Series is the most commonly used seal. It has an ingenious unitized body construction design with compact structure. The seal face is driven through "L" ring and the spring and allows for fast and easy installation and replacement. Elastomer drive ring grips shaft to provide positive sealing and drive without set screws or drive pins. There are no bonded joints and all the face materials are interchangeable. It is suitable for centrifugal, rotary, turbine pumps, and compressor, blenders, chillers, and other rotary equipments. Also highly recommended for duties with media containing solids such as waste water treatments, sewage application, agitators, pulp and paper, food processing, marine, many water-based and other general applications.

TYPE DL Dimensional Data

Code	ds	d1	d2	d3	d4	*L2	L3	*L1K
0100	10	22.5	24.0	18.6	21.1	14.5	10.0	24.5
0120	12	25.0	26.5	20.6	23.1	15.0	10.0	25.0
0140	14	28.5	30.0	22.6	25.1	17.0	10.0	27.0
0150	15	28.5	30.0	23.6	26.1	17.0	10.0	27.0
0160	16	28.5	30.0	24.6	27.1	17.0	10.0	27.0
0180	18	32.0	33.5	26.2	33.1	19.5	11.5	31.0
0190	19	37.0	38.5	27.6	34.1	21.5	11.5	33.0
0200	20	37.0	38.5	28.6	35.1	21.5	11.5	33.0
0220	22	37.0	44.5	32.6	39.1	22.5	11.5	33.0
0240	24	42.5	44.5	32.6	39.1	22.5	11.5	34.0
0250	25	42.5	44.5	33.6	40.1	23.0	11.5	34.5
0280	28	49.0	51.0	36.7	43.1	26.5	11.5	38.0
0300	30	53.5	51.0	38.6	45.1	26.5	11.5	38.5
0320	32	53.5	55.5	41.6	48.1	27.5	11.5	39.0
0330	33	53.5	55.5	41.6	48.1	27.5	11.5	39.0
0350	35	57.0	59.0	43.6	50.1	28.5	11.5	40.5
0380	38	59.0	61.0	48.6	56.1	30.0	14.0	44.0
0400	40	62.0	64.0	50.6	58.1	30.0	14.0	44.0
0420	42	65.0	68.0	52.6	60.1	30.0	-	44.0
0430	43	65.5	68.0	53.6	61.1	30.0	14.0	44.0
0450	45	68.0	71.0	55.6	63.1	30.0	14.0	44.0
0480	48	70.5	73.0	58.6	66.1	30.5	14.0	44.0
0500	50	74.0	77.0	61.6	70.1	30.5	15.0	45.5
0530	53	78.5	81.5	64.6	73.1	35.0	15.0	48.0
0550	55	81.0	84.0	66.6	75.1	35.0	15.0	50.0
0580	58	85.5	88.5	69.6	78.1	37.0	15.0	52.0
0600	60	88.5	91.5	71.6	80.1	38.0	15.0	53.0
0650	65	93.5	97.0	76.6	85.1	40.0	15.0	55.0
0680	68	96.5	100.0	79.6	90.1	40.0	18.0	58.0
0700	70	99.5	102.0	82.5	92.1	40.0	18.0	58.0
0750	75	107.0	111.0	87.5	97.1	40.0	18.2	58.2
0800	80	112.0	116.0	94.6	105.1	40.0	18.2	58.2
0850	85	120.0	124.0	99.6	110.1	41.0	18.2	59.2
0900	90	127.0	131.0	104.6	115.1	45.0	18.2	63.2
0950	95	132.0	137.0	109.6	120.1	46.0	17.2	15.7
01000	100	124.0	129.0	114.6	125.1	65.7	17.2	64.2

TYPE DL2 - DL2/Z Dimensional Data

Code	ds	d1	d2	d3	d4	*L2	L3	*L1K
0100	10	22.5	24.0	18.6	21.1	25.9	10.0	35.9
0120	12	25.0	26.5	20.6	23.1	25.9	10.0	35.9
0140	14	28.5	30.0	22.6	25.1	28.4	10.0	38.4
0150	15	28.5	30.0	23.6	26.1	28.4	10.0	38.4
0160	16	28.5	30.0	24.6	27.1	28.4	10.0	38.4
0180	18	32.0	33.5	26.2	33.1	30.0	11.5	41.5
0190	19	37.0	38.5	27.6	34.1	30.0	11.5	41.5
0200	20	37.0	38.5	28.6	35.1	30.0	11.5	41.5
0220	22	37.0	44.5	32.6	39.1	32.5	11.5	41.5
0240	24	42.5	44.5	32.6	39.1	32.5	11.5	44.0
0250	25	42.5	44.5	33.6	40.1	32.5	11.5	44.0
0280	28	49.0	51.0	36.7	43.1	35.0	11.5	46.5
0300	30	53.5	51.0	38.6	45.1	35.0	11.5	46.5
0320	32	53.5	55.5	41.6	48.1	35.0	11.5	46.5
0330	33	53.5	55.5	41.6	48.1	35.0	11.5	46.5
0350	35	57.0	59.0	43.6	50.1	35.0	11.5	46.5
0380	38	59.0	61.0	48.6	56.1	36.5	14.0	50.0
0400	40	62.0	64.0	50.6	58.1	36.0	14.0	50.0
0420	42	65.0	68.0	52.6	60.1	36.0	-	50.0
0430	43	65.5	68.0	53.6	61.1	36.0	14.0	50.0
0450	45	68.0	71.0	55.6	63.1	36.0	14.0	50.0
0480	48	70.5	73.0	58.6	66.1	38.0	14.0	50.0
0500	50	74.0	77.0	61.6	70.1	36.5	15.0	53.0
0530	53	78.5	81.5	64.6	73.1	36.5	15.0	51.5
0550	55	81.0	84.0	66.6	75.1	36.5	15.0	51.5
0580	58	85.5	88.5	69.6	78.1	41.5	15.0	56.5
0600	60	88.5	91.5	71.6	80.1	41.5	15.0	56.5
0650	65	93.5	97.0	76.6	85.1	41.5	15.0	56.5
0680	68	96.5	100.0	79.6	90.1	41.5	18.0	59.2
0700	70	99.5	102.0	82.5	92.1	48.7	18.0	67.7
0750	75	107.0	111.0	87.5	97.1	48.7	18.2	67.7
0800	80	112.0	116.0	94.6	105.1	48.0	18.2	66.2
0850	85	120.0	124.0	99.6	110.1	46.0	18.2	64.2
0900	90	127.0	131.0	104.6	115.1	51.0	18.2	69.2
0950	95	132.0	137.0	109.6	120.1	51.0	17.2	68.2
01000	100	124.0	129.0	114.6	125.1	51.0	17.2	68.2

Metric sizes, From 10 ..100 mm

Fitting length tolerance: ds 10..20 mm ±1.0; ds 22..30 mm ±1.5; ds 32..100 mm ± 2.0

*L2 = Standard seal working length, *L1K = Based on type and stationary seat G9.

Design and featuring : Complying with DIN24960

ELASTOMERIC BELLOWS ROTARY MECHANICAL SEAL FOR PLAIN SHAFT, SPRIG ROTATING

Pressure and Velocity Limits

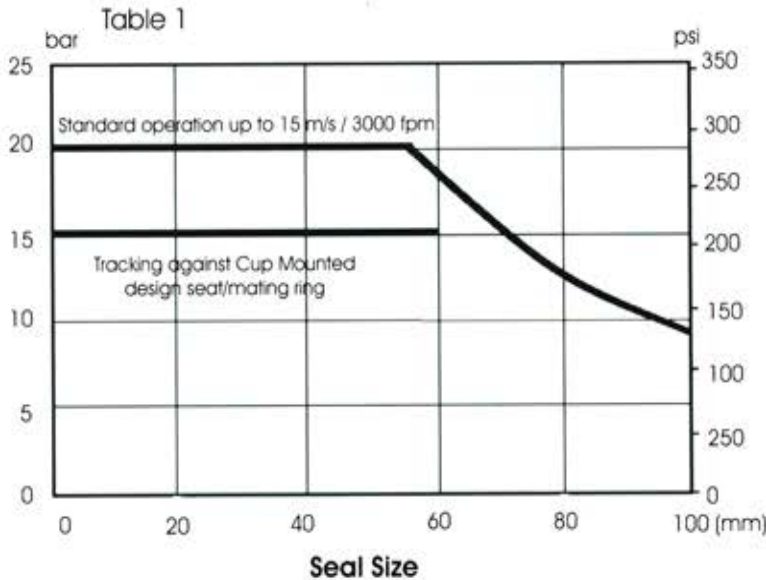

TYPE DL Mechanical Seal View

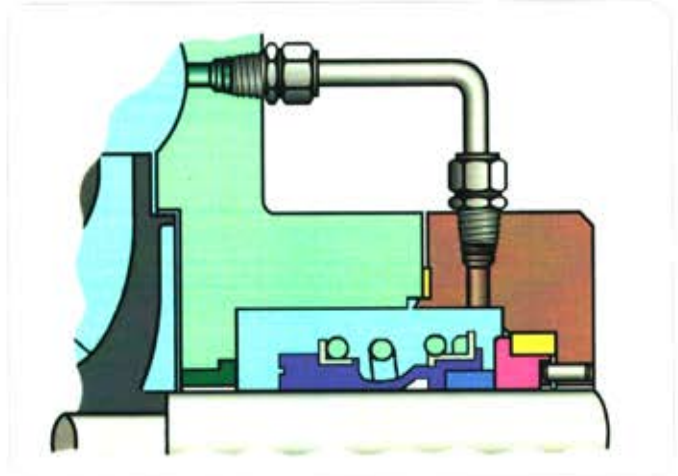

TYPE DL3 - DL3/Z Dimensional Data

Code	ds	d1	d2	d3	d4	*L2	*L3	L1K
0100	10	22.5	24.0	18.6	21.1	33.4	10.0	43.4
0120	12	25.0	26.5	20.6	23.1	33.4	10.0	43.4
0140	14	28.5	30.0	22.6	25.1	33.4	10.0	43.4
0150	15	28.5	30.0	23.6	26.1	33.4	10.0	43.4
0160	16	28.5	30.0	24.6	27.1	33.4	10.0	43.4
0180	18	32.0	33.5	26.2	33.1	37.5	11.5	49.0
0190	19	37.0	38.5	27.6	34.1	37.5	11.5	49.0
0200	20	37.0	38.5	28.6	35.1	37.5	11.5	49.0
0220	22	37.0	44.5	32.6	39.1	37.5	11.5	49.0
0240	24	42.5	44.5	32.6	39.1	42.5	11.5	54.0
0250	25	42.5	44.5	33.6	40.1	42.5	11.5	54.0
0280	28	49.0	51.0	36.7	43.1	42.5	11.5	54.0
0300	30	53.5	51.0	38.6	45.1	42.5	11.5	54.0
0320	32	53.5	55.5	41.6	48.1	47.5	11.5	59.0
0330	33	53.5	55.5	41.6	48.1	47.5	11.5	59.0
0350	35	57.0	59.0	43.6	50.1	47.5	11.5	59.0
0380	38	59.0	61.0	48.6	56.1	46.0	14.0	60.0
0400	40	62.0	64.0	50.6	58.1	46.5	14.0	60.0
0420	42	65.0	68.0	52.6	60.1	51.0	-	65.0
0430	43	65.5	68.0	53.6	61.1	51.0	14.0	65.0
0450	45	68.0	71.0	55.6	63.1	51.0	14.0	65.0
0480	48	70.5	73.0	58.6	66.1	51.0	14.0	65.0
0500	50	74.0	77.0	61.6	70.1	50.5	15.0	65.5
0530	53	78.5	81.5	64.6	73.1	59.0	15.0	74.0
0550	55	81.0	84.0	66.6	75.1	59.0	15.0	74.0
0580	58	85.5	88.5	69.6	78.1	59.0	15.0	74.0
0600	60	88.5	91.5	71.6	80.1	59.0	15.0	74.0
0650	65	93.5	97.0	76.6	85.1	69.0	15.0	84.0
0680	68	96.5	100.0	79.6	90.1	68.7	18.0	86.7
0700	70	99.5	102.0	82.5	92.1	68.7	18.0	86.7
0750	75	107.0	111.0	87.5	97.1	68.7	18.2	86.7
0800	80	112.0	116.0	94.6	105.1	78.0	18.2	96.2
0850	85	120.0	124.0	99.6	110.1	76.0	18.2	94.2
0900	90	127.0	131.0	104.6	115.1	76.0	18.2	94.2
0950	95	132.0	137.0	109.6	120.1	76.0	17.2	93.2
01000	100	124.0	129.0	114.6	125.1	76.0	17.2	93.2

Metric sizes. From 10 ..100 mm

Fitting length tolerance: ds 10..20 mm ±1.0; ds 22..30 mm ±1.5; ds 32..100 mm ± 2.0

*L2 = Standard seal working length. *L3 : Based on Stationary Seat G9.

Design and featuring : Complying with DIN24960

Material Availability and Technical Data

Bellows	P - E - V - A
Rotary Face	A - B - Q1 - Q2 - U3
Stationary Face	U3 - V - V2 - Q1 - Q2
Spring	G - M - F
Metal parts set	G - F
Max. Pressure	Up to 20 bar / 290 psi (upon G9 matin ring, Table 1, 2 & 3)
Max. Speed	Speed up to 15 m/s - 3000 fpm (Table 3)
Available Sizes	10 mm to 100 mm
Temperature Limit: (Upon Elastomer)	-40°C to +205°C / -40°F to +400°F

ELASTOMERIC BELLOWS ROTARY MECHANICAL SEAL FOR PLAIN SHAFT, SPRIG ROTATING



Installation

Recommended Chamfered Lengths Seat

Assemble under extra-clean condition.

Make sure all edges, the lead-in edge of the shaft or sleeve, shoulders and transitions which come in to contact with the sealing parts during installation are sufficiently chamfered or round off (Table 5). wet the clean shaft with some low-surface tension water (add detergent) or lubricate with silicon grease, then feed the bellows with a slight twist in clock wise direction on to the shaft.

Important Note:

No tightening, No force!
Never place rotary and stationary seals onto their seal faces; Rotary and stationary seals with seal face defects & worn out face or damaged secondary seals should not

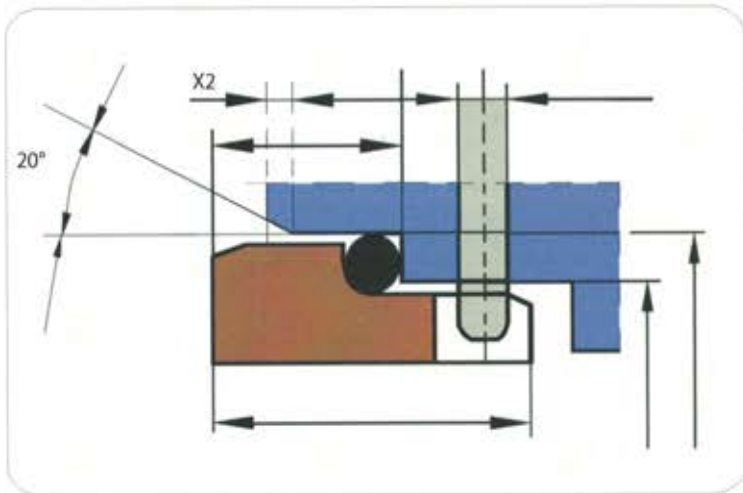

Recommended Chamfered Lengths Shaft

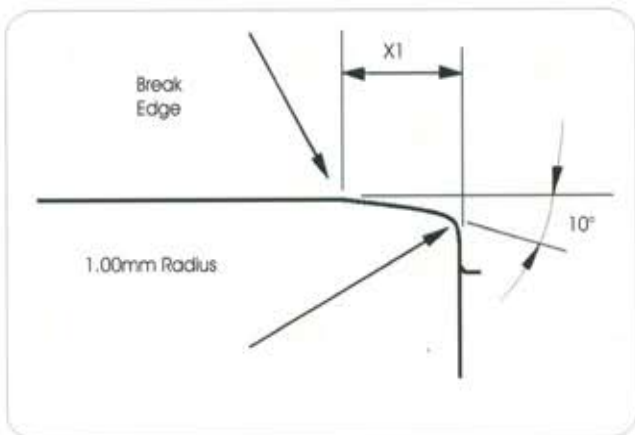

(X2) Seat Sizes:

- 1.5 mm chamfered length for size 10 to 18 mm
- 2.0 mm chamfered length for size 19 to 48 mm
- 2.5 mm chamfered length for size 50 to 75 mm
- 3.0 mm chamfered length for size 80 to 100 mm

((X1) Seal Sizes:

- 5 mm chamfered length up to size 25 mm
- 6.5 mm chamfered length for sizes 25 to 63 mm
- 8 mm chamfered length for sizes 70 to 100 mm

For ease of installation, the lead-on edge of the shaft or sleeve should be chamfered as shown.

TYPE DL



ELASTOMERIC BELLOWS ROTARY MECHANICAL SEAL FOR PLAIN SHAFT, SPRIG ROTATING

Multiplier Factors for Water and Hot Fluid

Table 2

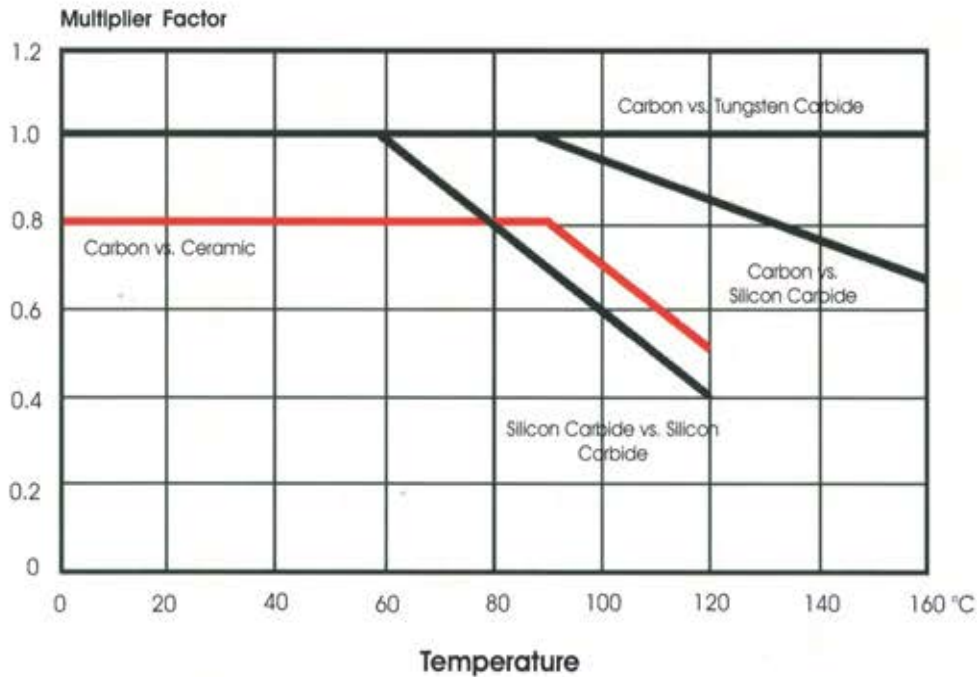

Pressure and Velocity Multiplier

Example

Table 3	Selection Consideration	Multiplier Factors
Sealed Fluid	Petrol, Kerosene or better	x 1.00
	Water, Aqueous Solutions Lighter Hydrocarbon (s.g 0.65)	x 0.75
Face and Seat Materials	Carbon vs. Silicon Carbide or Silicon Carbide Converted Graphite vs. Silicon Carbide	x 0.80
	Tungsten Carbide v. Tungsten Carbide	x 0.60
	Carbon vs. Aluminum Oxide or Austenitic Cast Iron	x 0.60
	Silicon Carbide vs. Silicon Carbide	x 0.50
Sealed Fluid Temperature	Up to 80°C /175°F	x 1.00
	80°C to 120°C/175°F to 250°F	x 0.90
	Above 120°C to 180°C/250°F to 355°F	x 0.80
	Above 180°C to 230°C/355°F to 445°F	x 0.65
Speed	Up to 1800rpm	x 1.00
	Above 1800 to 3600 rpm	x 0.85

Examples for Determining Pressure and Velocity Multiplier Factors Limit (Table 1 and 2):

Seal: 70mm diameter
 Product: Water
 Face and seat material: Silicon Carbide vs. silicon Carbide
 Operating temperature: +50°C/122°F
 Operating speed: 3600 rpm
 Using Pressure/Velocity Limits (Table 1), the maximum pressure would be 15 bars/217 psi

From (Table 2) Multiplier Factors tables, apply the multiplier factors for the specific service requirements:
 $15 \text{ bar (217 psi)} \times 0.75 \times 0.50 \times 1.00 \times 1.00 = 5.63 \text{ bar / 82 psi}$
 Therefore, for the example given the maximum operating pressure is 5.63 bar / 82 psi.



Multiplier Factors for Water and Hot Fluid

Table 2

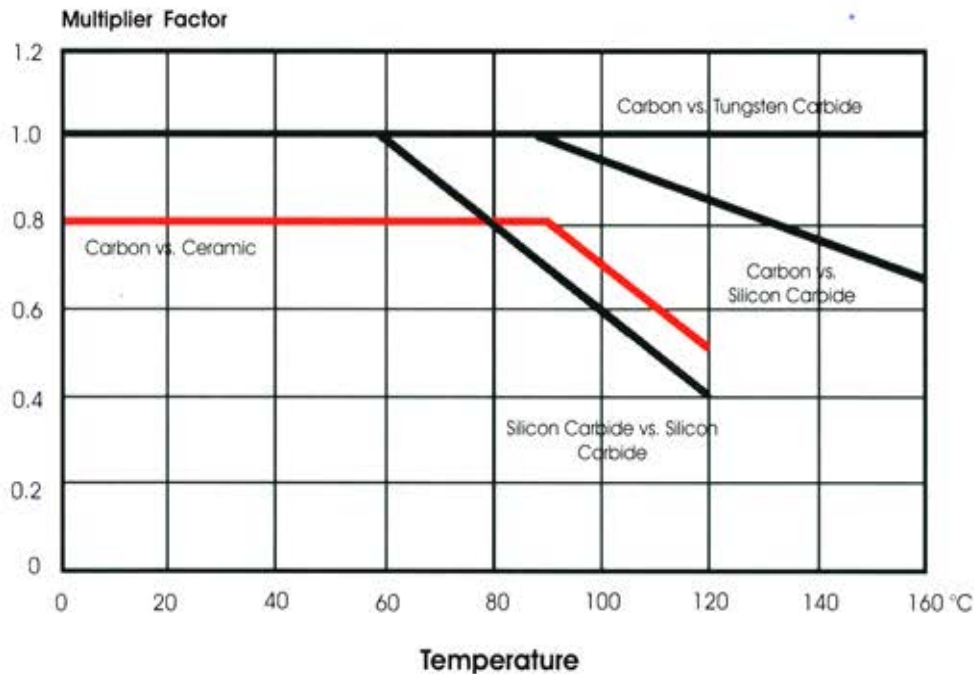

Pressure and Velocity Multiplier

Example

Table 3	Selection Consideration	Multiplier Factors
Sealed Fluid	Petrol, Kerosene or better	x 1.00
	Water, Aqueous Solutions Lighter Hydrocarbon (s.g 0.65)	x 0.75
Face and Seat Materials	Carbon vs. Silicon Carbide or Silicon Carbide Converted Graphite vs. Silicon Carbide	x 0.80
	Tungsten Carbide v. Tungsten Carbide	x 0.60
	Carbon vs. Aluminum Oxide or Austenitic Cast Iron	x 0.60
	Silicon Carbide vs. Silicon Carbide	x 0.50
Sealed Fluid Temperature	Up to 80°C / 175°F	x 1.00
	80°C to 120°C / 175°F to 250°F	x 0.90
	Above 120°C to 180°C / 250°F to 355°F	x 0.80
	Above 180°C to 230°C / 355°F to 445°F	x 0.65
Speed	Up to 1800rpm	x 1.00
	Above 1800 to 3600 rpm	x 0.85

Examples for Determining Pressure and Velocity Multiplier Factors Limit (Table 1 and 2):

Seal: 70mm diameter
 Product: Water
 Face and seat material: Silicon Carbide vs. silicon Carbide
 Operating temperature: +50°C/122°F
 Operating speed: 3600 rpm
 Using Pressure/Velocity Limits (Table 1), the maximum pressure would be 15 bars/217 psi

From (Table 2) Multiplier Factors tables, apply the multiplier factors for the specific service requirements:
 15 bar (217 psi) x 0.75 x 0.50 x 1.00 x 1.00 = 5.63 bar / 82 psi
 Therefore, for the example given the maximum operating pressure is 5.63 bar / 82 psi.

ELASTOMERIC BELLOWS ROTARY MECHANICAL SEAL FOR PLAIN SHAFT, SPRIG ROTATING



TYPE DL

Installation

Assemble under extra-clean condition.

Make sure all edges. The lead-in edge of the shaft or sleeve, shoulders and transitions which come in to contact with the sealing parts during installation are sufficiently chamfered or round off (Table 5). wet the clean shaft with some low-surface tension water (add detergent) or lubricate with silicon grease, then feed the bellows with a slight twist in clock wise direction on to the shaft.

Important Note:

No tightening, No force!
Never place rotary and stationary seals onto their seal faces; Rotary and stationary seals with seal face defects & worn out face or damaged secondary seals should not

Recommended Chamfered Lengths Seat

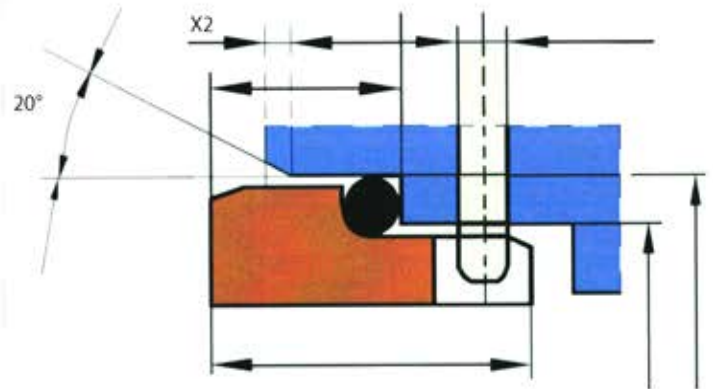

Recommended Chamfered Lengths Shaft

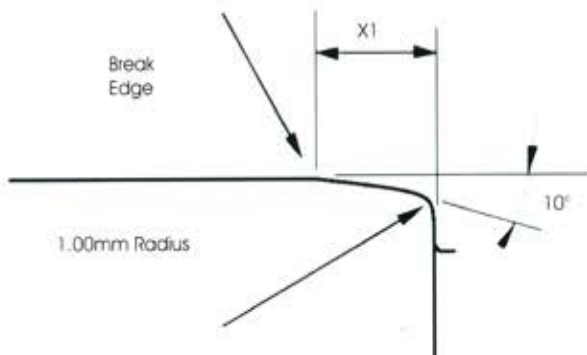

(X2) Seat Sizes:

- 1.5 mm chamfered length for size 10 to 18 mm
- 2.0 mm chamfered length for size 19 to 48 mm
- 2.5 mm chamfered length for size 50 to 75 mm
- 3.0 mm chamfered length for size 80 to 100 mm

((X1) Seal Sizes:

- 5 mm chamfered length up to size 25 mm
- 6.5 mm chamfered length for sizes 25 to 63 mm
- 8 mm chamfered length for sizes 70 to 100 mm

For ease of installation, the lead-on edge of the shaft or sleeve should be chamfered as shown.

ELASTOMERIC BELLOWS AND MULTI
SPRINGS MECHANICAL SEALS

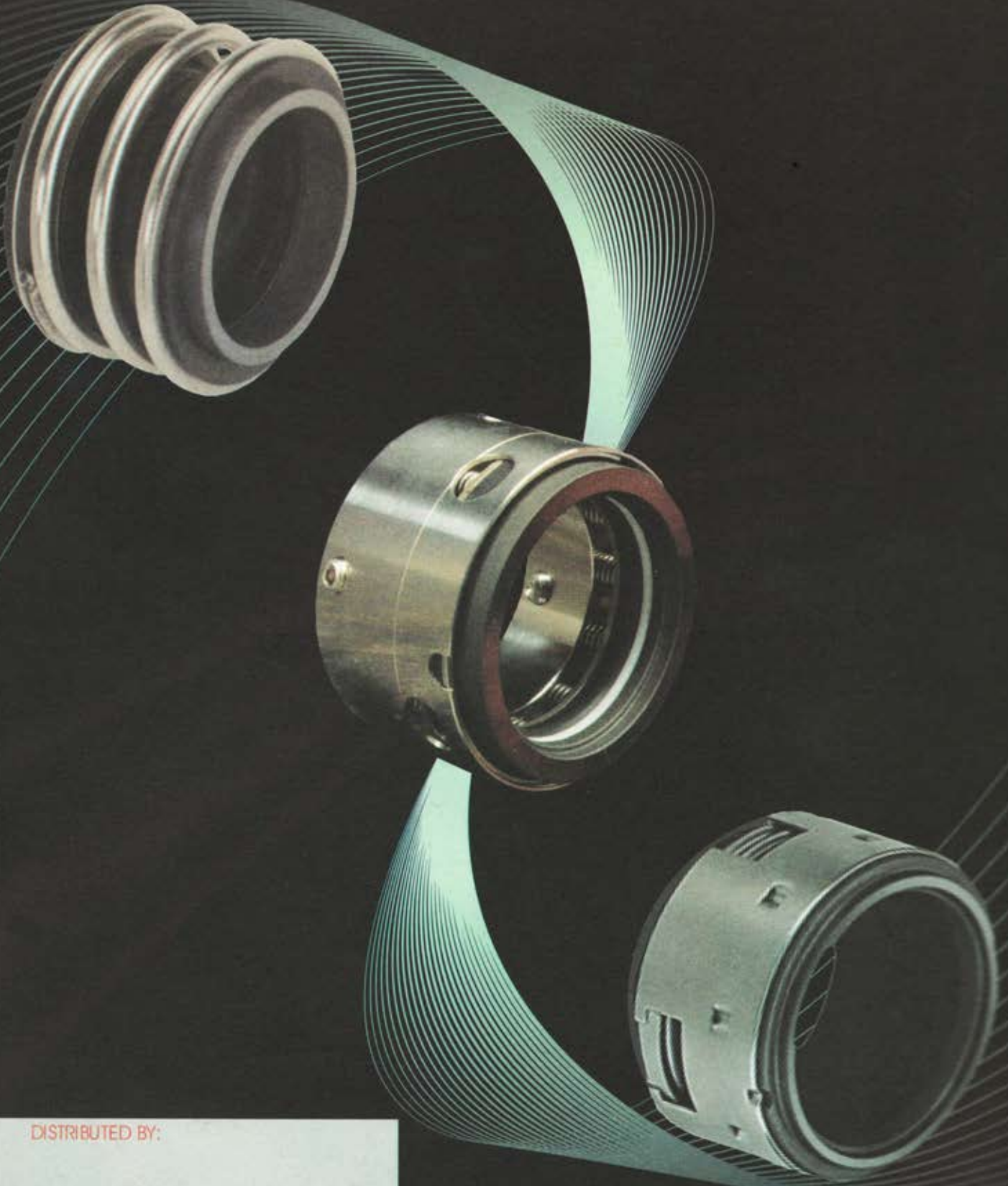

DISTRIBUTED BY:



Please contact DELCO if you require up to date specification.

All data in this catalogue could be copied and used by referring to the main source.

All the specification and sizes in this catalogue could be changed due to industrial configuration without any previous notification.

DELCO ROYAL MANUFACTURING INC. STN.

