

HBrinker Mechanical Seal

Pusher seals Mechanical Seal HB2N



Mechanical Seal HB2N

Operating range

Shaft diameter: $d_1 = 6 \dots 38 \text{ mm}$ (0.25" ... 1.5")

Pressure: $p_1 = 10 \text{ bar}$ (145 PSI)

Temperature: $t = -20 \text{ }^\circ\text{C} \dots 140 \text{ }^\circ\text{C}$ (-4 °F ... 355 °F)

Sliding velocity: $v_g = 15 \text{ m/s}$ (50 ft/s)

Axial movement: $\pm 1.0 \text{ mm}$



Materials

- Seal face: Carbon graphite resin impregnated (B)
- Seat G9: Silicon carbide (Q1, Q2),
- Special cast CrMo steel (S), Aluminium oxide (V)

Features

- For plain shafts
- Single seal
- Unbalanced
- Conical spring rotating
- ∇ Dependent on direction of rotation

Advantages

- Economical seal solution
- No damage of the shaft by set screws
- Short installation length possible (G16)

Recommended applications

- Pulp and paper industry
- Water and waste water technology
- Building services industry
- Water pumps
- Heating circulation pumps

HBrinker Mechanical Seal

Pusher seals Mechanical Seal HB2N

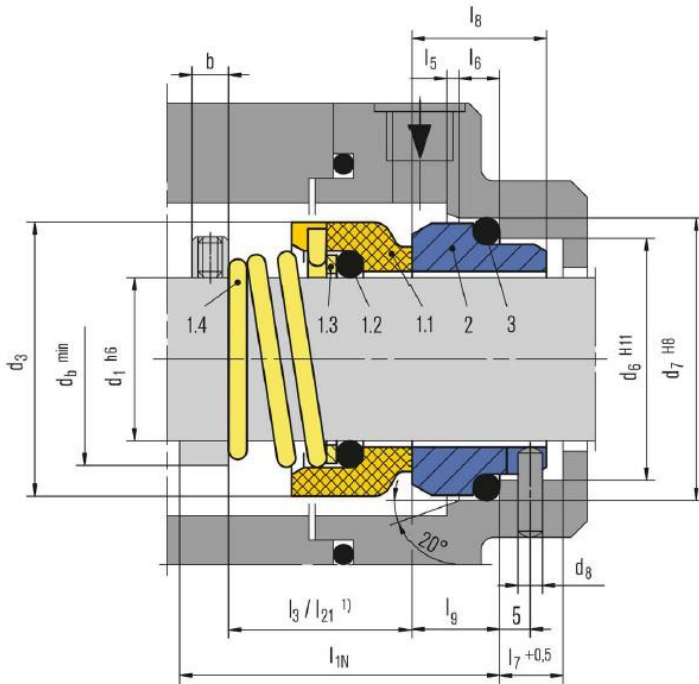

v

Item	Part no. to DIN 24250	Description
1.1	472	Seal face
1.2	412.1	O-Ring
1.3	474	Thrust ring
1.4	478	Righthand spring
1.4	479	Lefthand spring
2	475	Seat (G9)
3	412.2	O-Ring

HBrinker Mechanical Seal

Pusher seals Mechanical Seal HB2N



Dimension Table in millimeter

d ₁	d ₃	d ₆	d ₇	d ₈	d ₁₁	d ₁₂	d _b	d _b	l ₃ ¹⁾	l ₅	l ₆	l ₇
6	15	–	–	–	11.8	16.0	8	–	–	–	–	–
8	18	–	–	–	15.5	19.2	11	–	–	–	–	–
10	20	17	21	3	15.5	19.2	13	40	17.5	1.5	4	8.5
12	22	19	23	3	17.5	21.6	16	40	17.5	1.5	4	8.5
14	25	21	25	3	20.5	24.6	18	40	17.5	1.5	4	8.5
15	27	–	–	–	20.5	24.6	19	–	–	–	–	–
16	27	23	27	3	22.0	28.0	21	40	19.5	1.5	4	8.5
18	30	27	33	3	24.0	30.0	23	45	20.5	2.0	5	9.0
20	32	29	35	3	29.5	35.0	26	45	22.0	2.0	5	9.0
22	35	31	37	3	29.5	35.0	28	45	23.5	2.0	5	9.0
24	38	33	39	3	32.0	38.0	30	50	25.0	2.0	5	9.0
25	40	34	40	3	32.0	38.0	31	50	26.5	2.0	5	9.0
26	41	–	–	–	34.0	40.0	32	–	–	–	–	–
28	43	37	43	3	36.0	42.0	35	50	26.5	2.0	5	9.0
30	47	–	–	–	39.2	45.0	37	–	–	–	–	–
32	48	–	–	–	42.2	48.0	39	–	–	–	–	–
35	53	–	–	–	46.2	52.0	43	–	–	–	–	–
38	56	–	–	–	49.2	55.0	47	–	–	–	–	–

l ₈	l ₁₀	l ₁₂	l ₁₄	l ₁₅	l ₁₆	l ₁₈	l ₁₉	l ₂₁ ¹⁾	l ₂₈	b	R
–	–	6.5	5.6	1.2	3.8	–	–	10.9	–	–	1.2
–	–	8.0	7.0	1.2	3.8	–	–	15.5	–	–	1.2
17.5	7.5	7.5	6.6	1.2	3.8	–	–	15.9	6.6	8	1.2
17.5	7.5	8.0	7.0	1.2	3.8	–	–	16.0	6.6	8	1.2
17.5	7.5	8.0	7.0	1.2	3.8	–	–	16.0	6.6	8	1.2
–	–	7.5	6.6	1.2	3.8	–	–	17.4	–	–	1.2
17.5	7.5	8.5	7.5	1.5	5.0	–	–	19.0	6.6	8	1.5
19.5	8.5	9.0	8.0	1.5	5.0	15	7	20.5	7.5	8	1.5
19.5	8.5	8.5	7.5	1.5	5.0	15	7	22.0	7.5	8	1.5
19.5	8.5	8.5	7.5	1.5	5.0	15	7	23.5	7.5	8	1.5
19.5	8.5	8.5	7.5	1.5	5.0	15	7	25.0	7.5	8	1.5
19.5	8.5	8.5	7.5	1.5	5.0	15	7	26.5	7.5	8	1.5
–	–	9.0	8.0	1.5	5.0	–	–	26.5	–	–	1.5
19.5	8.5	10.0	9.0	1.5	5.0	15	7	26.5	7.5	8	1.5
–	–	11.5	10.5	1.5	5.0	15	7	25.0	–	–	1.5
–	–	13.0	10.5	1.5	5.0	15	7	28.5	–	–	1.5
–	–	13.5	11.0	1.5	5.0	15	7	28.5	–	–	1.5
–	–	13.0	10.3	1.5	5.0	16	8	32.0	–	–	1.5



HBrinker Mechanical Seal

Pusher seals Mechanical Seal HB2N

Seat alternatives

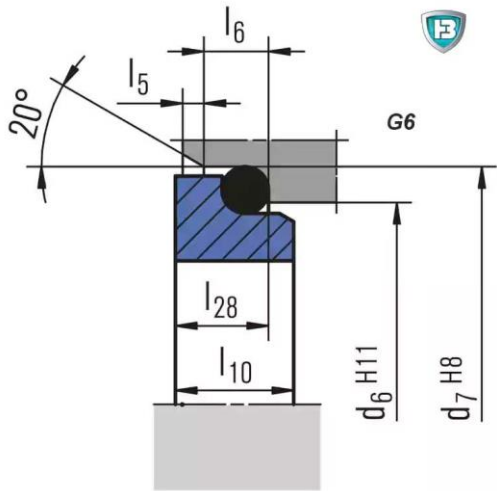

Seat G6

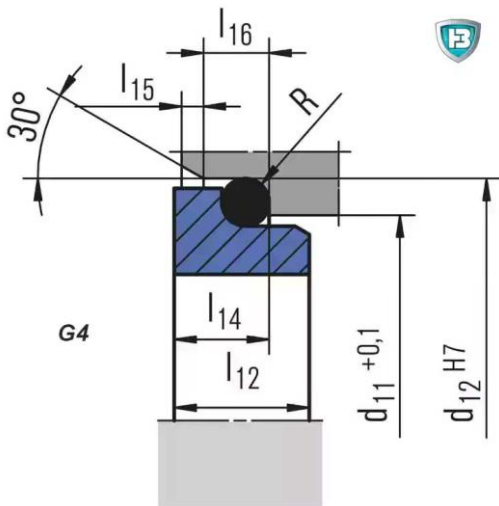

v
Seat G4

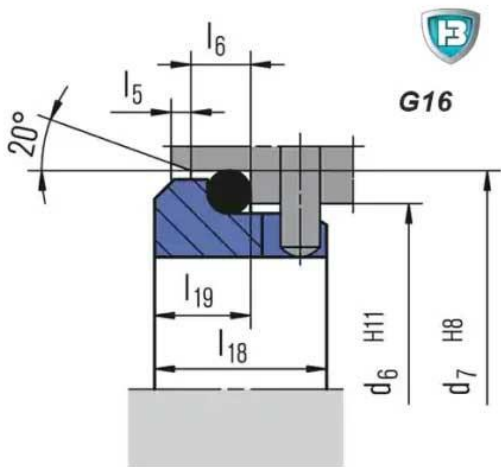

Seat G16

